

WH C4 Chain Hoist

The William Hackett WH C4 chain hoist meets and exceeds the requirements of the following international standards:

British Standard BS EN13157:2004 + A1:2009
American Standard ASME B30.16-2014
Australian Standard AS1418.2-1997
South African Standard SANS 1594:2007
NORSOK R-002: 2017.

The design and specification of the William Hackett WH C4 chain hoist includes:

- **WORKING LOAD LIMIT RANGE:** 500kg to 50 tonnes.
- **LIGHT LOAD CAPABILITY:** tested and certified at 2% of the chain hoist rated capacity.
- **TWIN PAWL:** fitted as standard.
- **SAFETY FACTOR:** 4:1.
- **SAFETY LATCHES:** hooks are fitted with heavy duty cast steel latches. The latch and hook tip are integrated creating a strong and robust hook closure.
- **HOOK OVERLOAD AND TRACEABILITY MARKS:** hooks have overload indicator marks either side of the hook throat (500kg to 10t). Both top and bottom hooks are embossed with a batch code, manufacturer's mark and the working load limit for full traceability and compliance to international standards.
- **HAND CHAIN JOINER:** a unique hand chain joiner is used as a quick and secure method of joining the hand chain.
- **HOOK HOUSING:** secured with socket head cap screws/hex head bolts and nyloc insert locking nuts to allow full inspection.
- **FLEETING/CROSS HAULING:** independently tested (test report 2550-7615) for fleeting or cross hauling applications up to 45° from the vertical without deration of the WLL.
- **LOAD CHAIN:** fitted with load chain that fully complies with international standard BS EN818-7 Grade T (8).
- **TEMPERATURE RANGE:** -20°C to +120°C
- **PROOF TESTED:** 500kg to 10 tonne hoists are proof tested to 1.5 times the Working Load Limit. 15 tonne to 50 tonne hoists are proof tested to 1.25 times the Working Load Limit.
- **OVERLOAD LIMITER:** available as an option upon request.
- **BOTTOM HOOK:** available with ball bearing adaptors as an option upon request.
- **MANUFACTURED AND PROOF TESTED** in the U.K.



Specifications

Single Fall

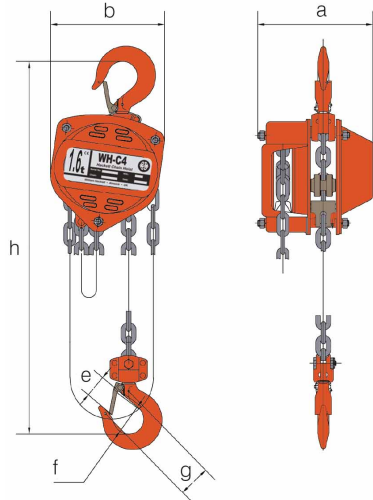

Multi Fall

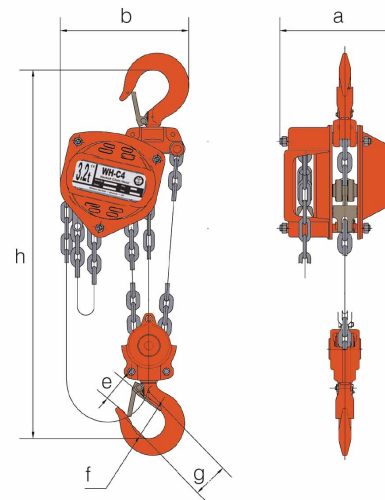

Part Code	WLL tonnes	No. of Falls	Load Chain mm	Hand Chain mm	Standard Lift m	a mm	b mm	e mm	f mm	g mm	h mm	Mass kg 3m HOL	Extra Weight per m kg
022.053	0.50	1	5 x 15	5 x 25	3	125	130	22.5	32	37	280	7.80	1.38
022.103	1.00	1	6 x 18	5 x 25	3	134	155	26.5	40	44	306	11.10	1.62
022.163	1.60	1	8 x 24	5 x 25	3	151	173	32.5	42	48	368	15.80	2.23
022.203	2.00	1	8 x 24	5 x 25	3	157	185	36.5	46	52	445	16.80	2.23
022.32D03	3.20	2	8 x 24	5 x 25	3	157	235	43.5	52	62	520	24.20	3.62
022.503	5.00	2	10 x 30	5 x 25	3	180	262	51.0	60	77	600	38.40	5.18
022.753	7.50	3	10 x 30	5 x 25	3	192	373	64.0	85	86	740	58.20	7.60
022.1003	10.00	4	10 x 30	5 x 25	3	180	365	64.0	85	86	760	68.90	9.52
022/1503	15.00	6	10 x 30	5 x 25	3	210	406	80.0	100	-	1000	116.70	13.86
022/2003	20.00	8	10 x 30	5 x 25	3	225	550	80.0	110	-	1150	149.50	19.03
022/3003	30.00	12	10 x 30	5 x 25	3	360	680	80.0	110	-	1250	230.00	27.71
022/5003	50.00	20	10 x 30	5 x 25	3	585	832	133.0	170	-	1700	750.00	45.80

The Mount
566 Eutruria Road
Newcastle under Lyme
ST5 0SU